

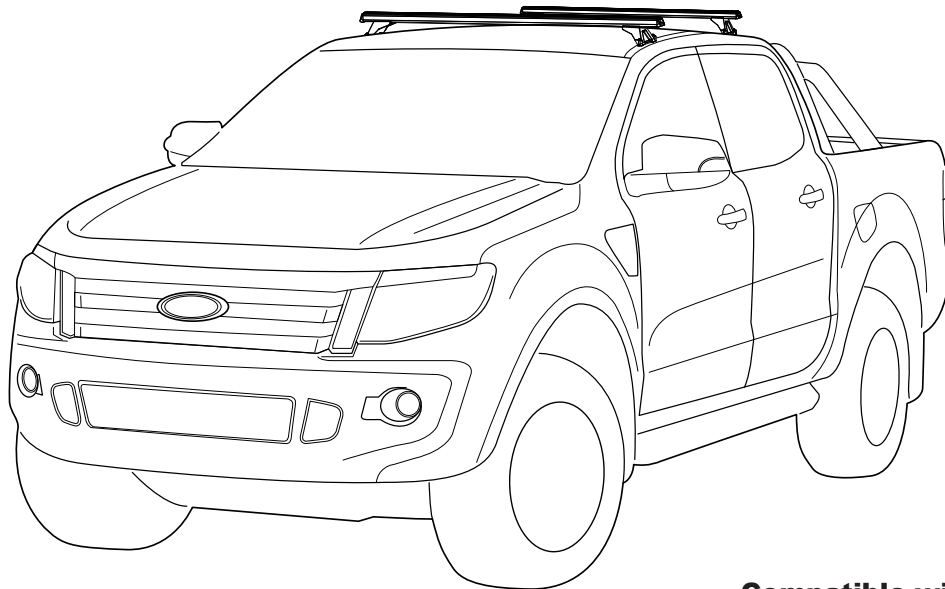

RHINO-RACK

RTS525 Ford Ranger PX/ Mazda BT50 - Two Cross Bar Track Mount System

Important: Please read these instructions carefully prior to installation.
Please refer to your fitting instruction to ensure that the roof racks are installed in the correct locations.
Check the contents of kit before commencing fitment and report any discrepancies.
Place these instructions in the vehicle's glove box after installation is complete.



Compatible with Mazda BT-50

Care Instruction: Wash vehicle roof prior to installing Rhino Tracks.

Important Information

Maximum carrying capacity: 100kg

Recommendations:

It is essential that all bolt connections be checked after driving a short distance when you first install your cross bars. Bolt connections should be checked again at regular intervals (probably once a week is enough, depending on road conditions, usage, loads and distances travelled). You should also check the cross bars each time they are re-fitted.

Make sure to fasten your load securely. Please ensure that all loads are evenly distributed and that the centre of gravity is kept as low as possible.

Use only non-stretch fastening ropes or straps.

Sensitivity to cross winds, behaviour in curves and braking.

The handling characteristics of the vehicle, changes when you transport a load on the roof. For safety reasons, we recommend you exercise extreme care when transporting wind-resisting loads; special consideration must be taken into account when braking.

Please remove cross bars when putting vehicle through an automatic car wash.

Load Ratings:

Maximum permissible load is 100kg per pair of cross bars (include the weight of the cross bars, 5kg). When cross bars are to be used in off-road conditions, please build a safety factor of 1.5 into this load limit. Although the cross bars are tested and approved to AS1235-2000, Australian road conditions can be much more rigorous. However, increasing the number of cross bars does not increase the vehicles maximum permissible roof loading.

Note for Dealers and Fitters:

It is your responsibility to ensure instructions are given to the end user or client.

Rhino-Rack
3 Pike Street, Rydalmere,
NSW 2116, Australia.
(Ph) (02) 9638 4744
(Fax) (02) 9638 4822

Document No: R200
Prepared By: Andy Wana
Authorised By: Chris Murty

Issue No: 05
Issue Date: 11/04/2013

These instructions remain the property of Rhino-Rack Australia Pty. Ltd. and may not be used or changed for any other purpose than intended.



RTS525 Ford Ranger PX/ Mazda BT50 - Two Cross Bar Track Mount System

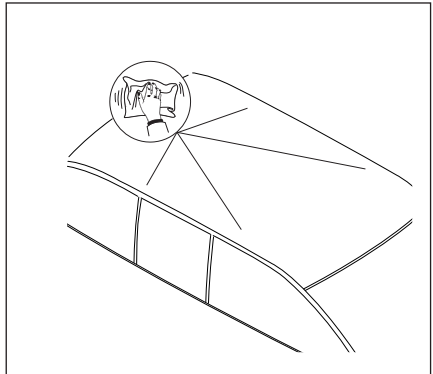
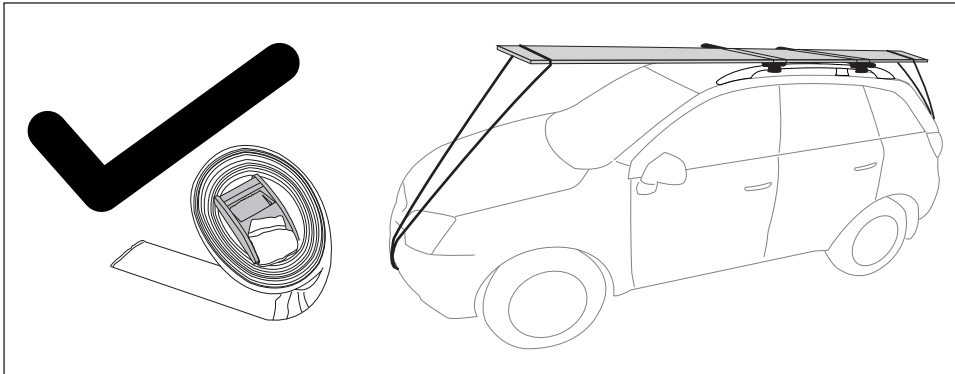
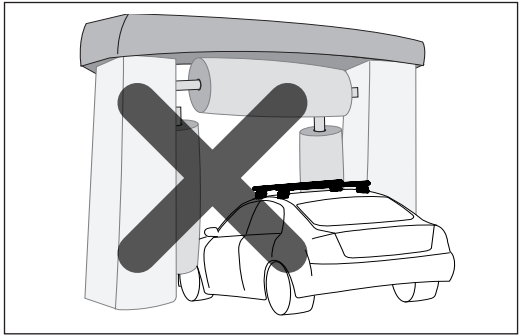
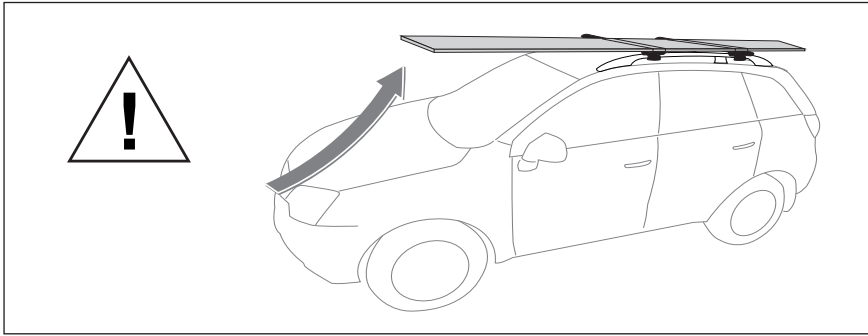

WARNING! Important Load Carrying Instructions

With utility vehicles, the cabin and the canopy move independently. Roofracks and vehicle can be damaged if the item transported is rigidly fixed at points on both the cabin and canopy. Instead, rigidly fix to either the cabin roofracks or the canopy roofracks.

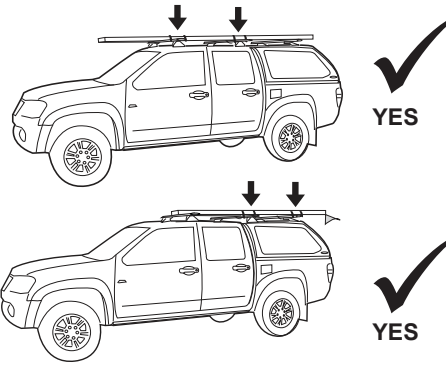
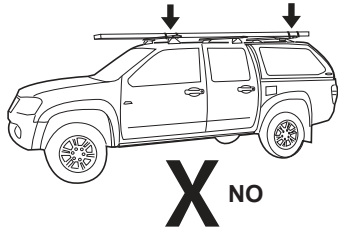

Parts List

Item	Component Name	Qty	Part No.
1	Track (Left and Right)	2	A528
2	End Cap Left Hand Side	2	CA1127
3	End Cap Right Hand Side	2	CA1128
4	01661-00619 Avdel Rivet	16	H008
5	Fitting Instruction	1	R200

Tools Required:

Pneumatic or Concertina	5mm drill bit.
Rivet gun.	Vacuum cleaner.
Masking tape.	Cold galvanizing solution & small brush.
Rubber Mallet.	Selleys Butyl Mastic.
Power or Cordless drill.	

SPECIAL NOTE:

Assistance by a second person is required to maintain accurate alignment of the Track extrusion while holes are marked out and drilled.

IMPORTANT Care Instruction:

Wash the roof prior to fitting the track mount system, especially the area the track will be mounting to. PLEASE READ THROUGH INSTRUCTIONS BEFORE FITTING.

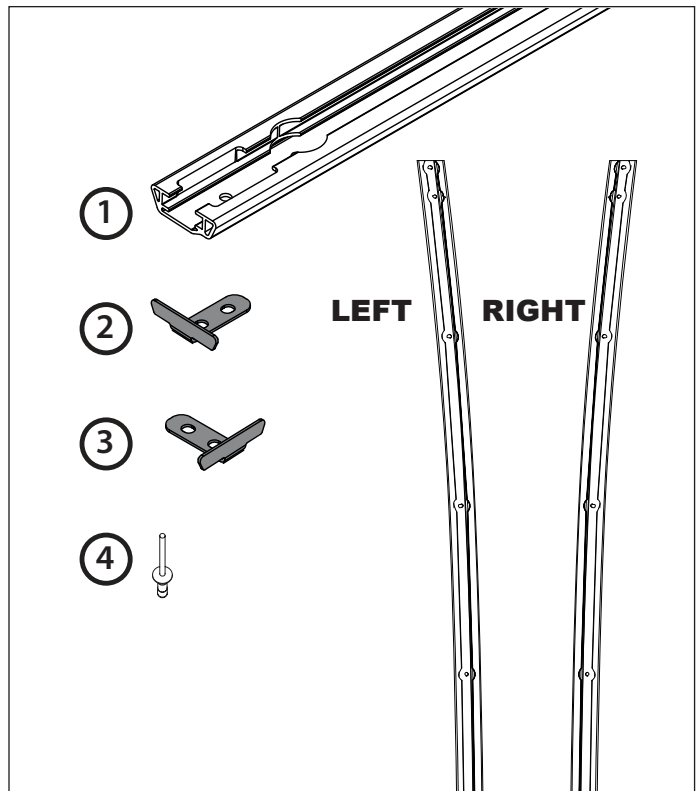



Fitting Instructions

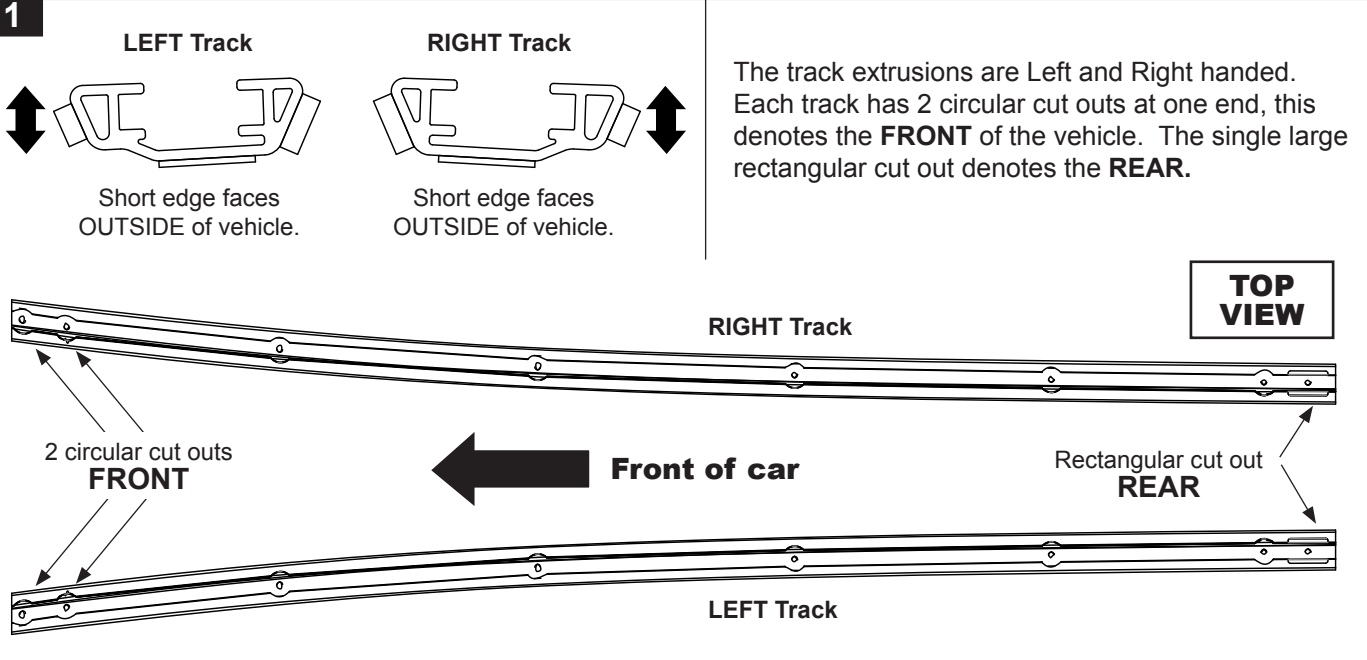

NOTE: WE RECOMMEND THAT YOU COMPLETELY INSTALL ONE TRACK AT A TIME.

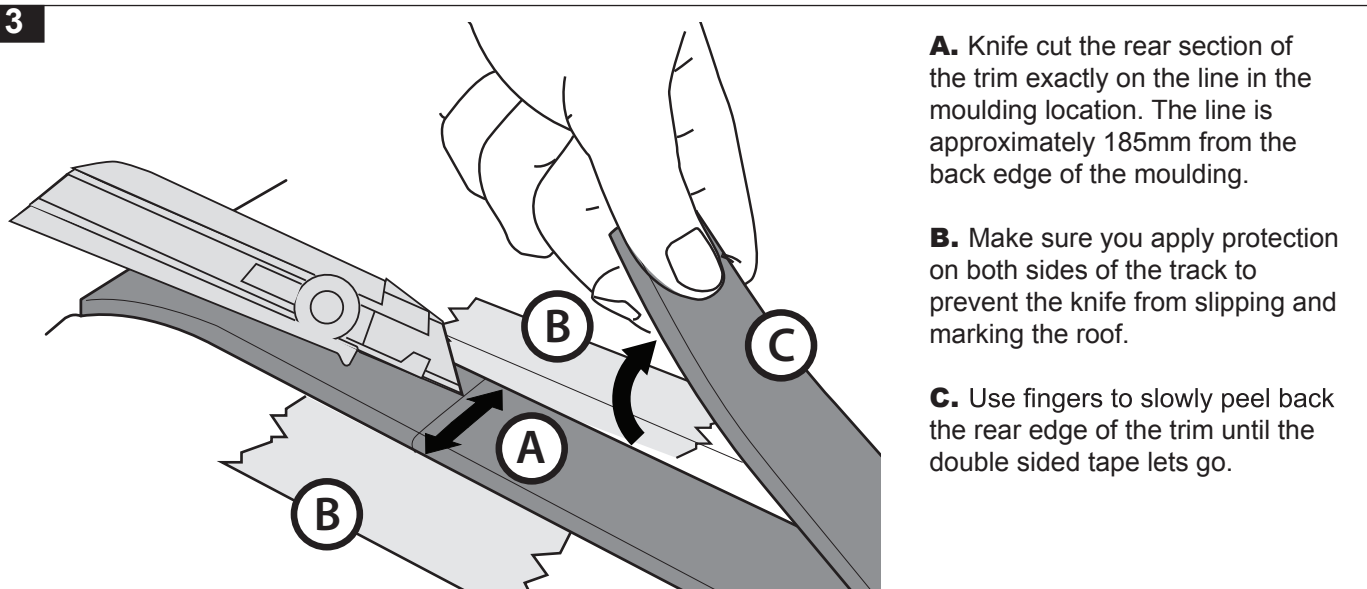
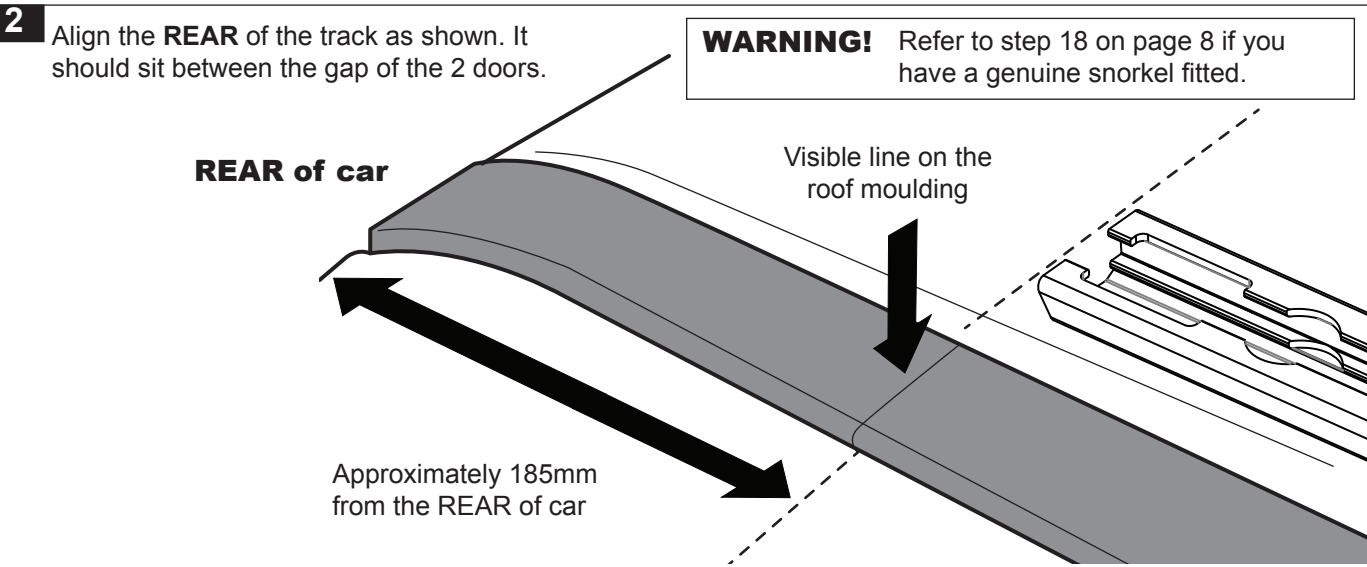



RTS525 Ford Ranger PX/ Mazda BT50 - Two Cross Bar Track Mount System

3

Mark the front edge of moulding by placing the track against it. Allow an **additional 4mm** for the end caps. Place a cut line on the front trim area. Continue to peel from the back (step 2) till trim and double tape is off the vehicle. **Any excess double sided tape left on the vehicle must be completely cleaned off for track fitment**



FRONT of car

REAR of car

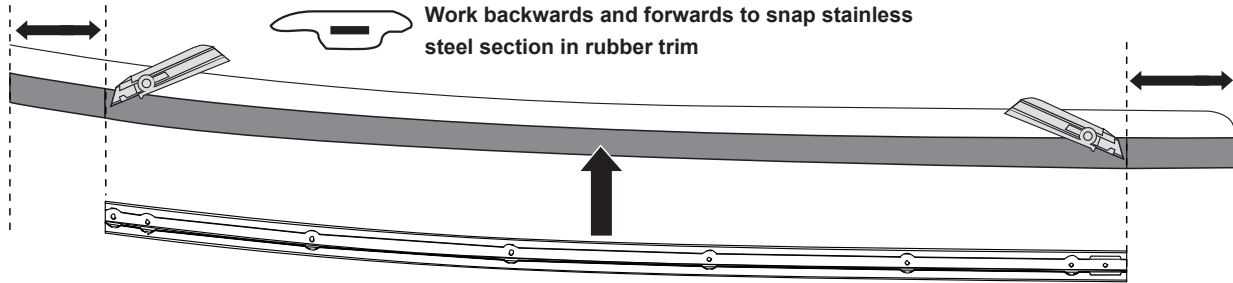

4

NOTE: (P1) refers to the person spot drilling.
(P2) refers to the person assisting.

- A. Maintain downward pressure on the track while spot drilling all holes.
- B. Person one (P1), with the assistance of a second person (P2). Hold the track firmly in position. Spot drill the first 4 holes. P2 to hold the track and maintain alignment of the 5th hole as P1 moves around towards the rear of the track. P2 and P1 hold the track while maintaining 5th hole alignment and P1 to continue spot drilling holes 5 - 8

Right FRONT
2mm spacing
from end of trim

Right REAR
2mm spacing
from end of trim

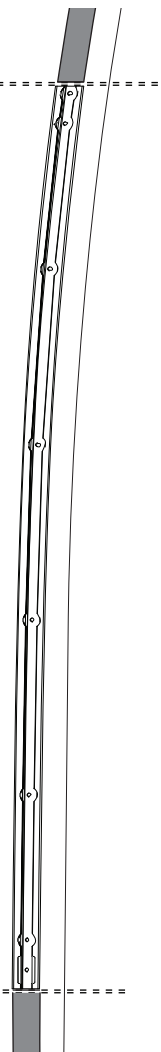

Maintain downwards
pressure on track.

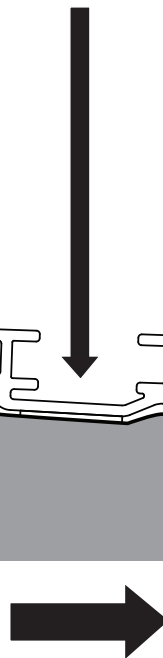

OUTSIDE of vehicle.

Use masking tape around door and window seals to prevent drill swarf entering these areas.

Hole 8.

Hole 1.

Right REAR

Spot drill the 8 track holes
starting from the Rear.



RTS525 Ford Ranger PX/ Mazda BT50 - Two Cross Bar Track Mount System

5



All 8 holes can now be drilled through. A drill stop must be used to prevent drilling through the hood lining on the inside. **Make sure that when drilling you hold the drill perpendicular to the roof angle.** The roof skin is approx. 2-3mm thick.

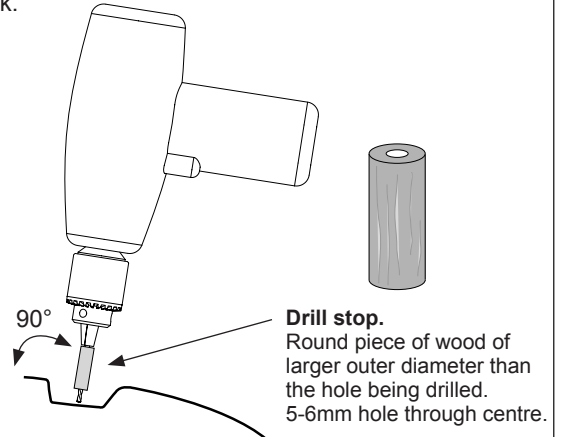

Drill stop.
Round piece of wood of larger outer diameter than the hole being drilled. 5-6mm hole through centre.

6

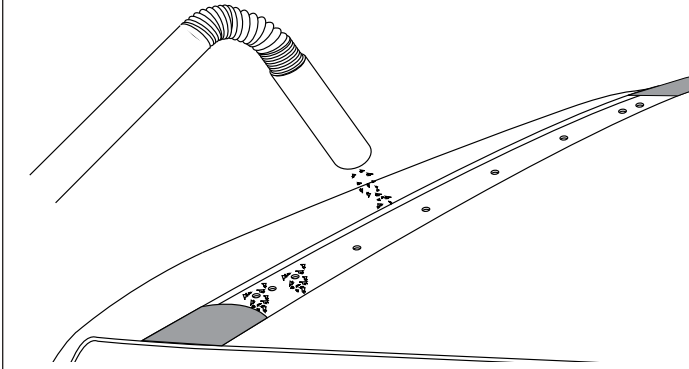

Use a vacuum to remove swarf to eliminate scratching. Wipe clean the installation area of the roof.



ALWAYS vacuum swarf.
NEVER blow swarf away with an air gun as it will cause rust

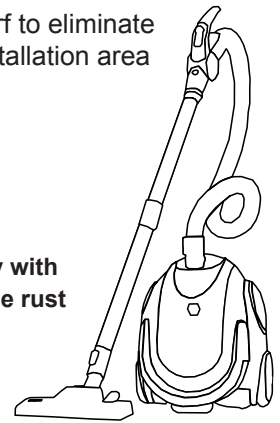

7

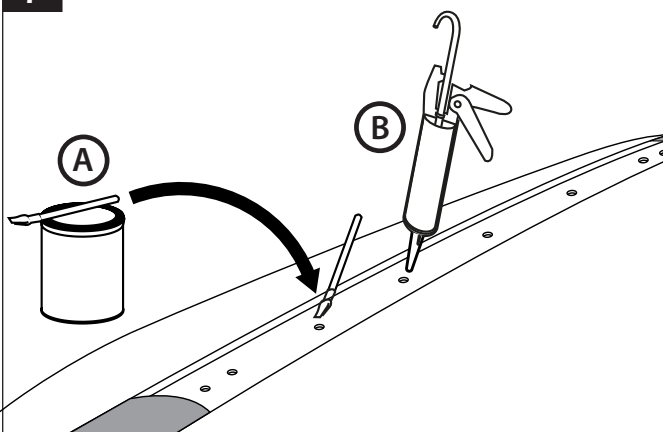

A. Apply a liberal amount of cold galvanizing solution to the inside and surrounds of all holes. Allow cold galvanizing solution to dry as per instructions (5-10 mins in hot, dry weather. Longer in cold, wet weather)

B. Apply a liberal amount of Selleys Butyl Mastic in and around each hole. This is an important step for waterproofing the roof area.

8

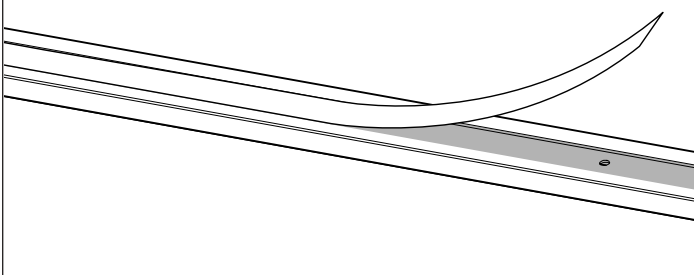

Peel the white backing strip off the track foam tape.



RTS525 Ford Ranger PX/ Mazda BT50 - Two Cross Bar Track Mount System

9 Insert the end caps at each end. Ensure that the profile of the end cap matches the ends as shown

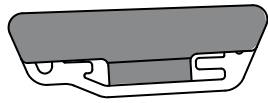

Align End Caps to Track Profile

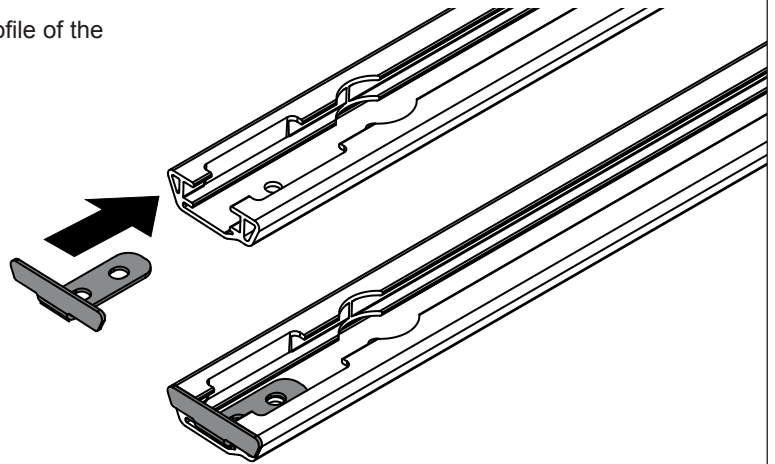
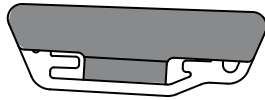

10 Line up and place all 8 rivets in their respective holes. Pay extra attention to the 5th hole (from the front) where the air bag module resides. With the assistance of a second person to maintain track alignment start riveting from the centre rivet. Follow the numerical riveting order as shown below. Holes 6 and 8 will have the end caps.

FRONT of car

End cap.

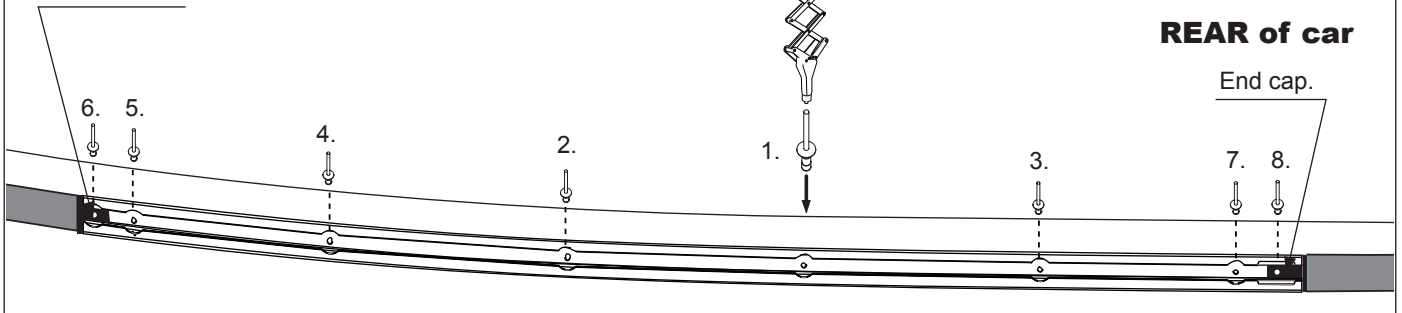

REAR of car

End cap.

To be used with RTL500 Leg Kit (SOLD SEPARATELY)

11 Locate dowel nut into aluminium housing. Slide into track. Slide to approximate position of where you want the cross bars.

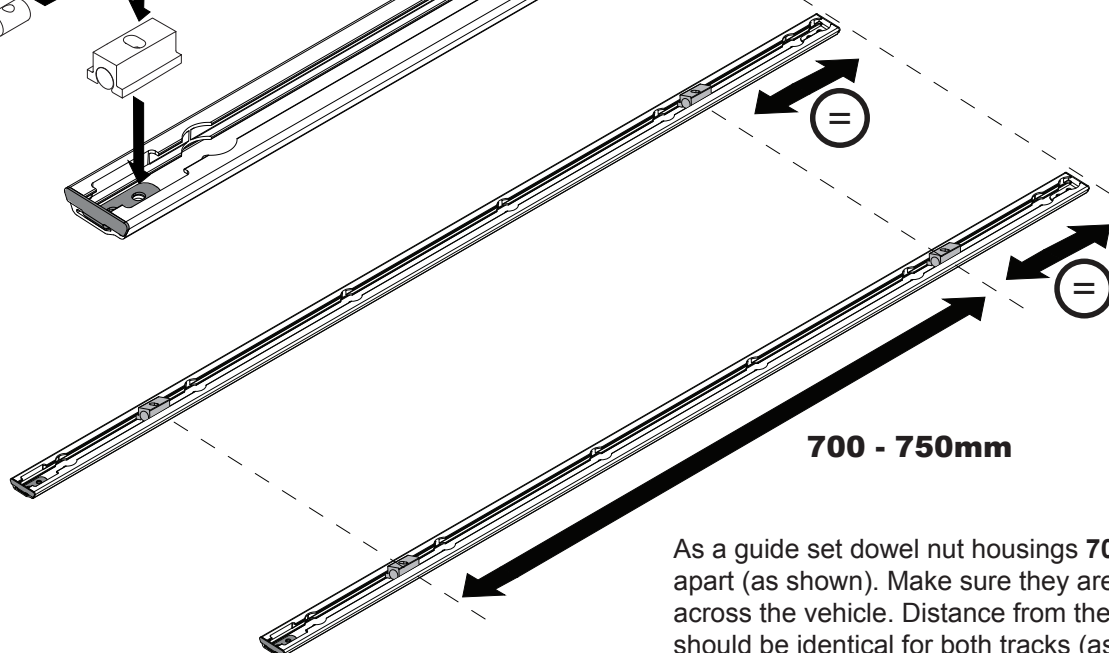
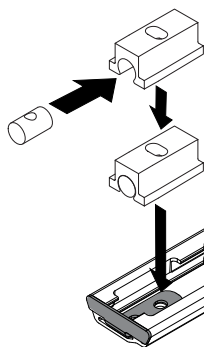

700 - 750mm

As a guide set dowel nut housings **700-750mm** apart (as shown). Make sure they are parallel across the vehicle. Distance from the rear end cap should be identical for both tracks (as shown).



RTS525 Ford Ranger PX/ Mazda BT50 - Two Cross Bar Track Mount System

12

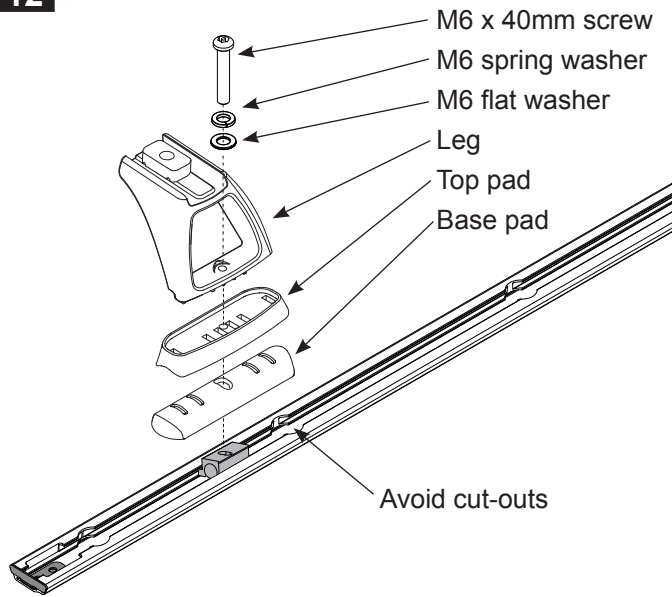

Attach the legs to track using supplied screws and washers. Finger tighten only.

Make sure to that aluminium dowel nut housing is not placed under cut-out holes in the track.

13

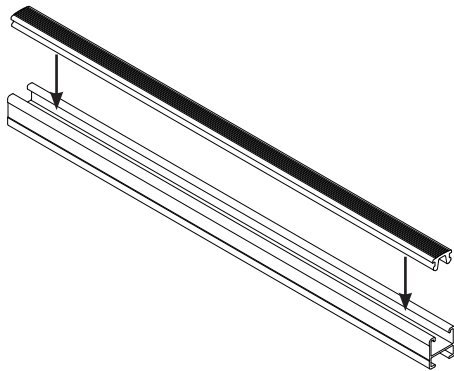

Insert crossbar rubber.

14

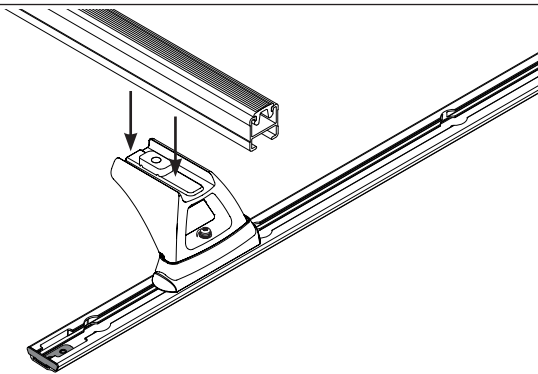

Attach crossbar.

Channel nut must fully locate across the bar.

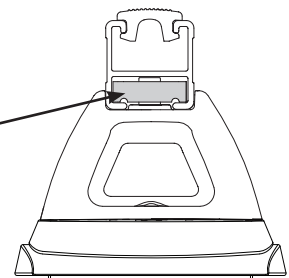

15

Adjust cross bar overhang to be equal both sides. Once adjusted tighten M10 crossbar bolts to **15-16 Nm (132-141 lbf.in)**. Then fasten M6 security screws to **3-4 Nm (26-35 lbf.in)**

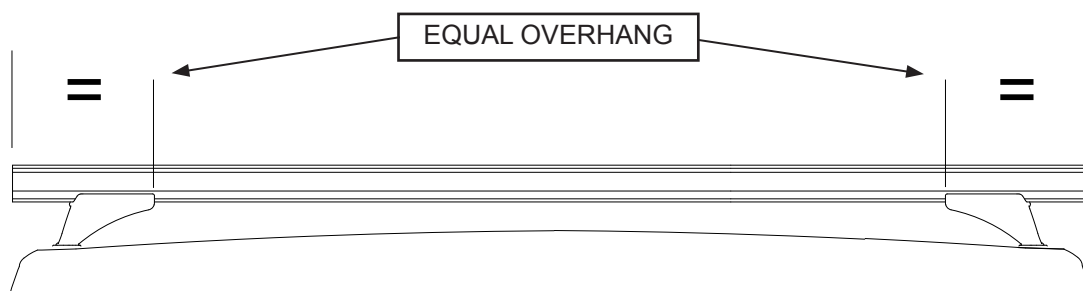



RTS525 Ford Ranger PX/ Mazda BT50 - Two Cross Bar Track Mount System

16

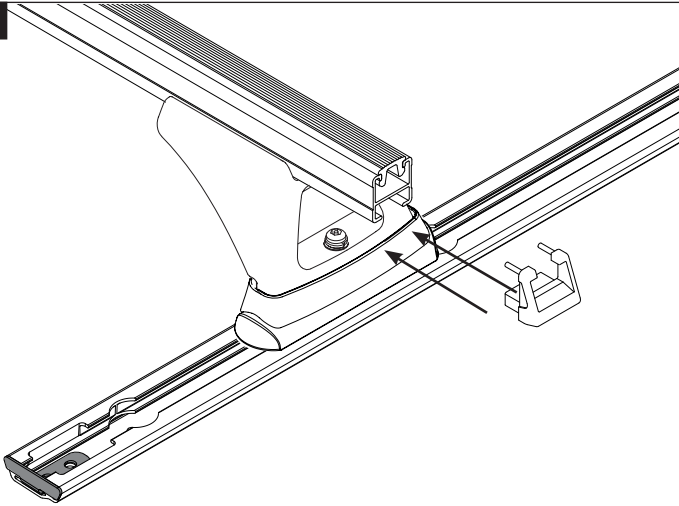

Fit end caps. A rubber mallet may be used to knock them in.

17

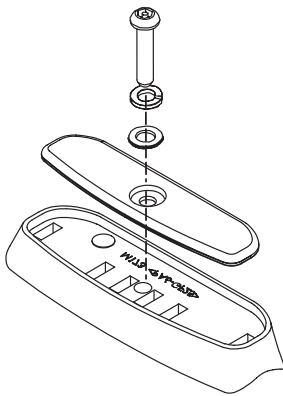

Pad cover plates are provided for when crossbars are removed.

18

If you have factory snorkel fitted. Align the **REAR** of the track as shown. It should sit between the gap of the 2 doors.

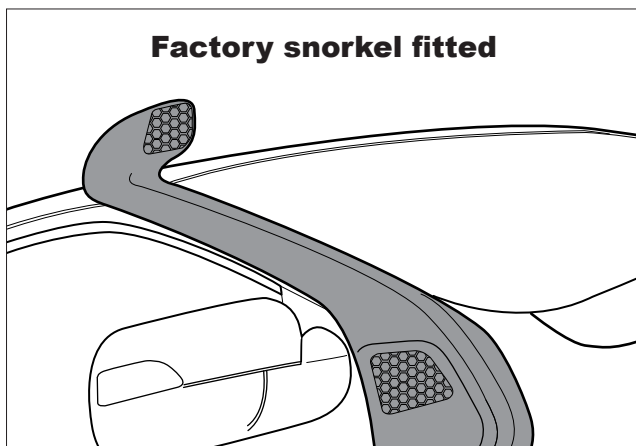

Factory snorkel fitted

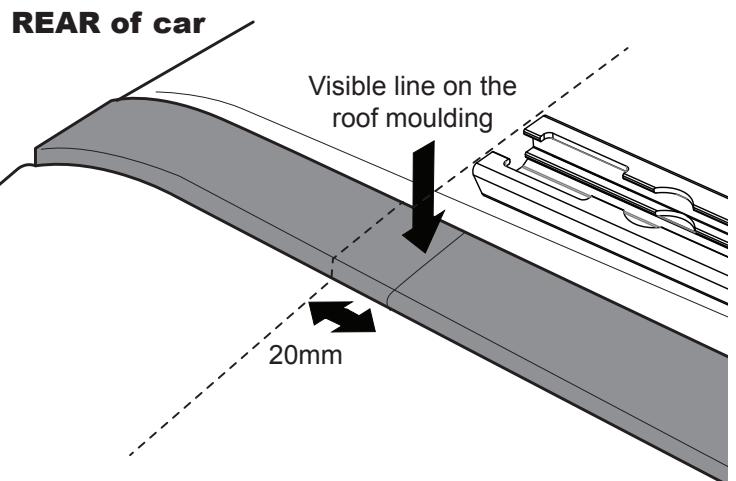

REAR of car

Visible line on the roof moulding

20mm

WARRANTY INFORMATION

Rhino-Rack warrants your new product against any manufacturing faults for the period specified on our website, provided the terms and conditions of the warranty are met. Some exclusions apply. To qualify for warranty cover, you must fill out the online warranty registration form. You should ensure that you retain your original proof of purchase, which will be required for any warranty claim.

For all warranty terms and conditions, please visit the Rhino Rack website for details

www.rhinorack.com/warranty